



Development of setup for human energy expenditure rate for ergonomic design of thresher

SRIKANTHNAIK J¹, PRAMOD KUMAR SHARMA^{1*} and H L KUSHWAHA¹

ICAR-Indian Agricultural Research Institute, New Delhi 110 012, India

Received: 25 September 2020; Accepted: 08 February 2021

Keywords: Ergonomics, Human Energy, Paddy thresher, Solar Energy

A number of hand tools and agricultural machines require rotational power operation in Indian farms (Ram 2008). Many interesting human power conversion machines are developed in the field in recent years (Mohurle *et al.* 2016). To study human-machine relationship an human powered flywheel (experimental setup) were need to develop. Healthy humans power can sustain about 75 W (0.1 hp) for a complete 8-hour period, while an athletes can sustain about 300W (0.4 hp). Therefore, this human power gives an alternative source of energy to operate different applications such as home appliances, to operate water pumps, and agricultural activities. Flywheel operated machines such as paddy thresher, chaff cutter, winnower etc. are used by Indian farm workers in the farms. Odd postures in performance of farm activities may cause musculoskeletal disorders. Leg muscles are strongest and longest part in the human body may results less drudgery and low heart rate, oxygen consumption rate, energy expenditure rate and body part discomfort score. To study a relationship between human and power, the human powered flywheel were developed for rotary power generation by pedaling action (Modak and Khope 2013, Padghan *et al.* (2014), Sonkhaskar *et al.* 2015). A foot operated rotary power generation was evaluated ergonomically based on physiological (heart rate, oxygen consumption and energy expenditure) and postural parameter (Body part discomfort score and Overall discomfort score) (Ram 2008) in which the operators performed at different mode of operation at different mechanical output. From the experimental results, it was revealed that a bicycle with pedaling mode got best mode of operation at all mechanical output. In view of above the present study was undertaken.

An experimental setup consist of frame which is

mounted with flywheel (40 cm dia), a pedal made for the rotation of flywheel through chain drive mechanism (Fig 1). The belt were provided around the flywheel through which a load cell (TX-200 HMM-Hi-tech) was connected at one end of the frame and the other end, belt pass through a pulley with loading pan at the frame opposite site. A load cell display at other connected end displays the reading of load, during experiment. The power transmission was selected through chain drive pedaling action. The complete structure of experimental setup (Fig 1) was fabricated at Workshop of Division of Agricultural Engineering, IARI, New Delhi (2019–20).

The important human body dimensions' were measured with the help of anthropometer. For the experiments, six subjects of age group between 23-25 years were selected from available internal division students. Out of six, three are male and another three are female of same age groups. For better movement of flywheel always depends on how much force applied during pedal stoke. Therefore to achieve maximum applied pedal force the knee angle should be at 120°, the step heights were calculated by multiplying 0.16 times the subject's height for achieving maximum leg force to pedaling (Agarwal 2008).

Before start of the experiment, subjects were asked to take 30 min rest to achieve resting pulse rate. After achieving resting pulse rate, there is no further reduction on Heart rate. Then subject can start experiment, the experiments were conducted about 5 min with the help of polar heart rate monitor for measurement of heart rate. After completing experiments, heart rate recorded data from polar heart rate monitor were transmitted to computer with help of infrared interface. From the average working heart rate the oxygen consumption rate were determined using equation given by Singh *et al.* (2008).

$$\text{OCR} = 0.0114 \times \text{AWHR} - 0.68 \quad (1)$$

where, OCR, Oxygen Consumption Rate (l/ m); AWHR, Average Working Heart Rate.

The Energy Expenditure Rate (EER) of subject was calculated by multiplying Oxygen Consumption Rate (OCR) which is equal to 20.88 kJ/m (Nag *et al.*1980).

Present address: ¹ICAR-Indian Agricultural Research Institute, New Delhi. *Corresponding author e-mail: pks_ageg@iari.res.in.

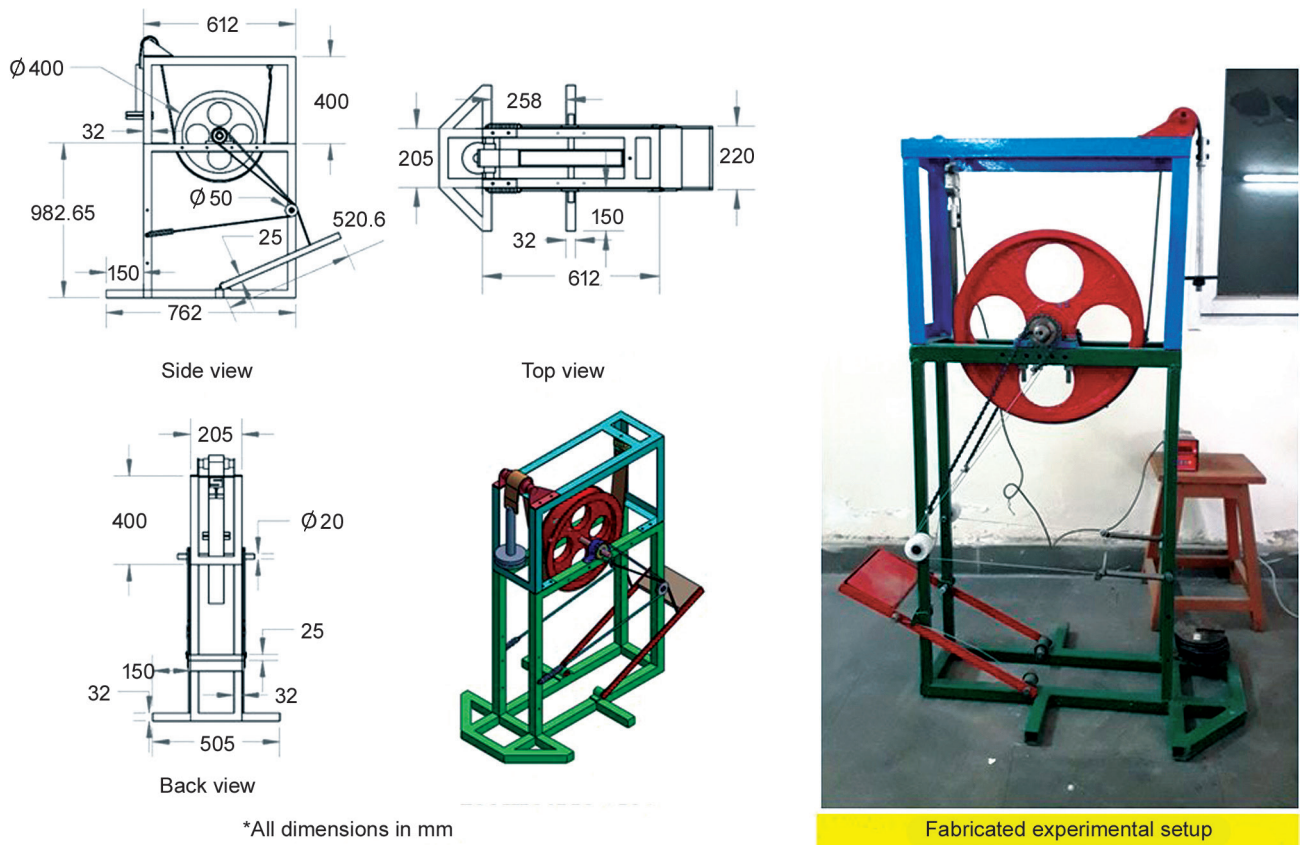

Fig 1 Design drawing of developed prototype foot operated rotary power generation.

The flywheel mechanical output (kj/sec) was determined with help of equation (Ram 2008) as given below:

$$\text{Mechanical output} = \frac{2\pi \times r \times f \times n}{1000} \quad (2)$$

where, r , Radius of flywheel (m); f , Indicated load of load cell (N); n , flywheel revolution.

The experimental data were analyzed using SAS (Statistical Analysis Software) software for analysis of variance (ANOVA) tests. Data was analyzed statistically using procedure of F-test and to compare treatment mean difference least significant difference (LSD) at $P \leq 0.05$ was used.

All six selected subjects' anthropometric dimensions were measured. The weight of female varied from 41.69–63.63 kg and the weight of male varied from 59.65–79.68 kg. The height of male subjects varied from 168.18–181.55 cm and for female subjects from 142.96–165.30 cm. With the help of anthropometer all important dimensions were measured. From the study, it was found that the anthropometric dimensions are varied due to variation of subject's age (Marsh *et al.* 1999), weight and gender (Ozcelik *et al.* 2004). The step height of 5th percentile of female value and 95th percentile of male dimensions was taken. The values for 5th percentile of female were 22.8 cm, 95th percentile of male was 29 cm and the average step height was 25.96 cm. These design values are taken

for selecting an optimum step height as per experimental design. Based on physiological and postural parameter on experimental setup (rotary power generation) used for determining effective step height the capacity of solar module was selected.

Data showed that the mean working heart rate values are found to be lower at step height 25.96 cm (89.28–113.61 beats/min), moderate at step height 22.8 cm (89.44–123.06 beats/min) and highest at step height 29 cm (101.94–125.5 beats/min) respectively. The effect of working heart rate was found significantly lower with step height 25.96 cm than both step height 22.8 cm and step height 29 cm under rotary power generation (Table 1). The step height, subject and mechanical output was found to affect working heart rate under rotary power generation. Results (Fig 2) showed that the mean oxygen consumption rate values are lower at step height 25.96 cm (0.33–0.61 l/min), moderate at step height 22.8 cm (0.34 – 0.72 l/min) and highest at step height 29 cm (0.48–0.75 l/min) respectively. It was also found that the oxygen consumption rate increase with mechanical output at all step height. The step height, subject and mechanical output was found to significantly affect the oxygen consumption rate under rotary power generation. The effect of oxygen consumption rate was found significantly lower with step height 25.96 cm than both step height 22.8 cm and step height 29 cm under rotary power generation (Table 1).

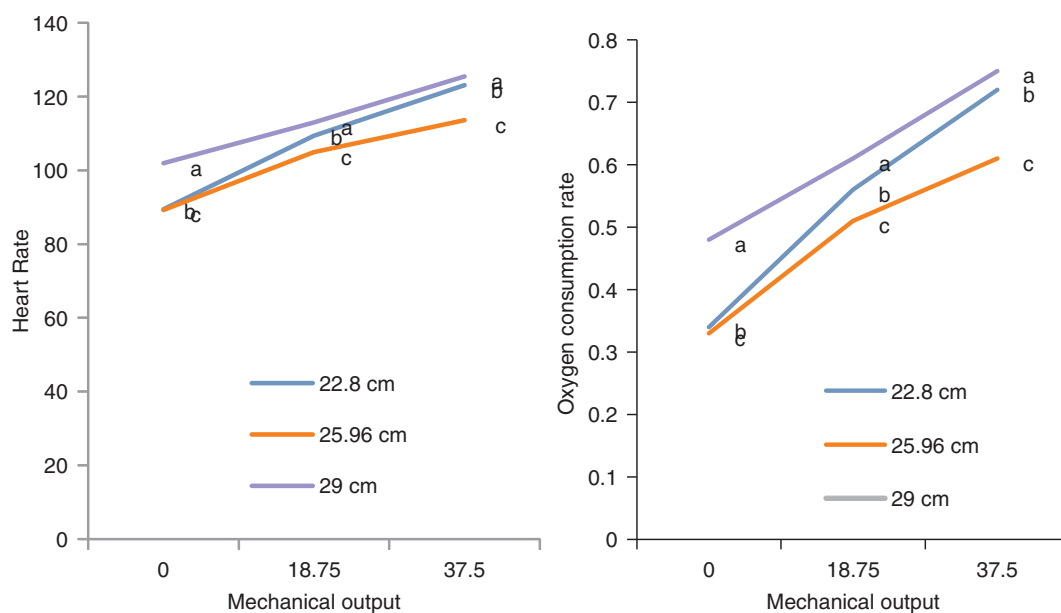

Fig 2 Effect of mechanical output (W) and step height on subject's heart rate (beats/min) and oxygen consumption rate (l/min). **Different letter on line marked are significantly different (based on LSD=0.05).

Data showed that the mean energy expenditure rate values are lower at step height 25.96 cm (6.94–12.72 kJ/min), moderate at step height 22.8 cm (6.96–14.98 kJ/

min) and highest at step height 29 cm (9.98–15.57 kJ/min) respectively. The step height, subject and mechanical output was found to significantly affect energy expenditure rate under rotary power generation. The effect of energy expenditure rate was found significantly lower with step height 25.96 cm than both step height 22.8 cm and step height 29 cm (Table 1) under rotary power generation. Results showed that the

Table 1 Effect of mechanical output (W), subjects and step height (cm) on working heart rate (beat/min), oxygen consumption rate (l/min), energy expenditure rate (kJ/min) and body part discomfort score under rotary power generation

Independent variables (Treatment)	Working heart rate (beat/min)	Oxygen consumption rate (l/min)	Energy expenditure rate (kJ/min)	Body part discomfort score
<i>Step height</i>				
22.8 cm	107.29 ^b	0.5362 ^b	11.18 ^b	11.57 ^b
25.96 cm	102.59 ^c	0.4844 ^c	10.10 ^c	10.02 ^c
29 cm	113.48 ^a	0.6092 ^a	12.71 ^a	12.32 ^a
Mean	107.78	0.5432	11.33	11.30
LSD ≤ 0.05	0.6254	0.0082	0.1715	0.4078
<i>Subject</i>				
A	109.59 ^a	0.5648 ^a	11.76 ^a	10.69 ^d
B	109.03 ^a	0.5581 ^a	11.64 ^a	11.39 ^{a,b,c}
C	107.88 ^b	0.5451 ^b	11.37 ^b	11.70 ^{a,b}
D	107.07 ^b	0.5359 ^b	11.18 ^b	10.86 ^{c,d}
E	107.44 ^b	0.5396 ^b	11.26 ^b	11.30 ^{b,c}
F	105.70 ^c	0.5162 ^c	10.77 ^c	11.89 ^a
Mean	107.78	0.5432	11.33	11.30
LSD ≤ 0.05	0.8844	0.0116	0.2426	0.5767
<i>Mechanical output</i>				
0 W	93.55 ^c	0.3820 ^c	7.96 ^c	7.26 ^c
18.75 W	109.09 ^b	0.5568 ^b	11.62 ^b	10.81 ^b
37.5 W	120.72 ^a	0.6911 ^a	14.42 ^a	15.84 ^a
Mean	107.78	0.5432	11.33	11.30
LSD ≤ 0.05	0.6254	0.0082	0.1715	0.4078

** Different letter on means of treatment marked are significantly different (LSD=0.05)

17.25), respectively. The effect of body part discomfort score was found significantly lower with step height 25.96 cm than both step height 22.8 cm and step height 29 cm (Table 1) under rotary power generation. The step height, subject and mechanical output was found to significantly affect body part discomfort score under rotary power generation.

At different step height of pedal operation, it was observed that working heart rate, oxygen consumption rate, energy expenditure rate and body part discomfort score increase with increase in mechanical output at all step height. The similar trends were observed by Ram, 2008. At step height 25.96 cm of pedal operation, energy expenditure rate is graded as “light” as per categorization given by Nag *et al.* (1980).

SUMMARY

This paper presents results of study on response of the most significant design parameter to optimize rotary power generation. From the experiment results it was found that at all mechanical output the step height of 25.96 cm was found best. At mechanical output 37.5W of step height 25.96 cm, the working heart rate, oxygen consumption rate, energy expenditure rate and body part discomfort score are 113.61 beat/min, 0.61 l/min, 12.72 kj/min (211.99 W) and 17.25 respectively. Based on this energy expenditure rate, the capacity of the solar module was selected as 200W.

REFERENCES

- Agrawal K N. 2008. ‘Ergonomical investigations of pedal operated paddy thresher. Ph D thesis, Indian Institute of Technology Kharagpur, India.
- Astrand P O, Ekblom B, Messing R, Stallin B and Stenberg J. 1965. Intra- Arterial blood pressure during exercise with different muscle group. *Journal of Applied Physiology* **20**: 253–56.
- Corlett E N and Bishop R P. 1976. A technique for assessing postural discomfort. *Ergonomics* **19**: 175–82.
- Khop P B and Modak J P. 2013. Development and performance evaluation of a human powered flywheel motor operated forge cutter. *International Journal of Scientific and Technology research* **2**(3): 146–49.
- Marsh G D, Paterson D H, Govindasamy D and Cunningham D A. 1999. Anaerobic power of the arms and legs of young and older men. *Experimental Physiology* **84**: 589–97.
- Mohurle M P, Deshmukh D S and Patil P D. 2016. Human power using bicycle mechanism as an alternative energy source: A critical review. *International Conference on Global Trends in Engineering, Technology and Management*.
- Nag, P K, Sebastian N C and Malvankar M G. 1980. Occupational workload of Indian Agricultural workers. *Ergonomics* **23**: 91–102.
- Ozceli O, Aslan M, Ayar A and Kelestimur H. 2004. Effects of body mass index on maximal work production capacity and aerobic fitness during incremental exercise. *Physiological Research* **53**: 165–70.
- Padghan K K, Pitale A K, Modak J P and Narkhedkar P. (2014). Human powered flywheel motor by using quick return ratio one mechanism. *International Journal of Advanced Technology in Engineering and Science* **2**(5).
- Ram R. 2008. ‘Ergonomic evaluation of foot operated rotary power generation’. M Tech. thesis, Indian Agricultural Research Institute New Delhi, India.
- Singh S P, Gite L P, Majumdar J and Agarwal N. 2008. Aerobic capacity of Indian farm women using sub-maximal exercise technique on tread mill. *Agricultural Engineering International: the CIGR E journal*. Manuscript MES 08 001. Vol. X, 1 – 10.
- Sirohi B S and Kulkarni S D. 1983. On the performance efficiency of the sickle for the manual harvesting of crops. *International Journal for Developmental Technology* **1**: 231–38.
- Sonkhaskar Y M, Swapnil S A and Abhinav M P. 2015. Human powered flywheel motor driven process units: A review. *International Journal of Innovative Research in Science, Engineering and Technology*.