

## RESEARCH ARTICLE

# Determination of engineering properties of selected animal feed and fodder materials

Ankit Deep, Hima John, Priyanka, Pradyuman Barnwal, Madan Lal Kamboj and Surender Singh Lathwal

Received: 06 October 2022 / Accepted: 07 December 2022 / Published online: 20 April 2023

© Indian Dairy Association (India) 2023

**Abstract:** The traditional ways of handling feed and fodder in a commercial dairy farm are labour intensive, tiresome and also leads to huge expenses as labour charges. Therefore, there is a need of mechanised feed and fodder distribution unit in order to reduce the human drudgery and other expenses. Thus, an attempt was made to determine the engineering properties (moisture content, bulk density, angle of repose and coefficient of internal friction) of feed which would be affecting the design of a mechanised feed and fodder unit. Three feed materials viz., oat green, wheat straw and concentrate mixture were selected for study. The angle of repose varied from  $24.78 \pm 0.34$  to  $37.79 \pm 0.76^\circ$ , the coefficient of friction from  $0.187 \pm 0.024$  to  $2.628 \pm 1.612$  depending on the moisture content and the bulk density of the selected materials. The coefficient of external friction was determined for different fabrication materials including wooden/ply board, galvanized iron, aluminium, mild steel and stainless steel and the maximum coefficient of external friction was offered to the feed materials by ply board followed by mild steel.

**Keywords:** Animal feed and fodder, Engineering properties, Angle of repose, Coefficient of friction

## Introduction

According to the 20<sup>th</sup> Livestock Census – 2019, India's total livestock population was 535.78 million, up by 4.6% from the previous Census in 2012 (DAHD, 2019). India is the world leader

in milk production, although animal productivity is low (1538 kg/year) compared to global average (2238 kg/year), which can be linked to malnutrition due to the huge deficit of animal feed (Vijay et al. 2018). There is no way to sustain cattle husbandry without addressing the challenges of fodder and feed resource development in the country. Due to rising competition between other land uses for cultivable land, further increase in the acreage of fodder crops is not viable (Kumar et al. 2012).

Fodder production in India varies greatly across the country, and its use is determined by cropping pattern, climate, socioeconomic conditions, and the type of cattle. Cattle and buffaloes are often fed fodder from cultivated regions, with collected grasses and top feeds supplementing it to a small extent (Shashikala et al. 2017). Fodder crops are cultivated or harvested for feeding the animals in the form of forage (cut green and fed fresh), silage (preserved under anaerobic conditions) and hay (dehydrated/dried green). Sorghum (2.6 M ha) and Egyptian clover (1.9 M ha) account for approximately 54% of the total cultivated fodder area in the kharif and rabi seasons, respectively (Dagar, 2017). But due to regional and seasonal variation various other crops are cultivated for animal feed purposes. At ICAR-NDRI, Karnal during research trials period oats and wheat were in cropping season and were available to be used as animal feed, hence they were selected for measurement of their engineering properties instead.

Healthy and nutritious feed is important for animal health and productivity. Nowadays, small and marginal dairy farms are no more self-sustaining and/or commercially viable due the huge expenses in terms of labour charges and other maintenance activities. Hence, there is a trend to shift towards large commercial dairy farming practices. In commercial dairy farming, a huge amount of feed is required to be handled. Handling huge quantities of feed manually is tiresome and labour intensive operation in addition to large amounts of feed likely to be wasted during handling. So, it is beneficial to handle the feed materials mechanically instead of opting manual handling. Design and development of feed and fodder handling machines would require a basic knowledge of engineering properties of feed material intended to be handled. Physical and engineering properties are important to understand the behaviour of materials while

---

ICAR-National Dairy Research Institute, Karnal, Haryana

Ankit Deep (✉)  
Dairy Engineering Division  
ICAR-National Dairy Research Institute, Karnal, Haryana  
Email: ankit.deep@gmail.com

handling, transportation and storage (Puchalski and Brusewitz (1996); Makavana et al. (2018)). The properties like angle of repose, coefficient of internal and external friction, bulk density and moisture content are some of the important properties which affect conveying characteristics. Seville et al. (1997) explained that the frictional behaviour of biomass grinds in all engineering applications is described by two independent parameters: the coefficient of internal friction, and the coefficient of wall friction. They explained that the coefficient of internal friction determines the stress distribution within particles undergoing strain, and the coefficient of external friction describes the magnitude of the stresses between the particle and the walls of its container. Material properties such as moisture content and particle size affect the frictional properties and densification performance of an individual feedstock (Larsson, 2010). The angle of repose is used in the design of equipment for the processing of particulate solids mainly in the design of an appropriate hopper or silo to store the material, or to size a conveyor belt for transporting the material. The angle of repose is also crucial in correctly calculating the stability of vessels (Bhople et al. 2017).

Engineering properties of feed and fodder materials are key design parameters of storage and handling equipment. Properly designed feed distribution and feeding units help to reduce the losses. As feed material is required to be conveyed while handling, a basic knowledge of how a feed material would behave in certain given conditions could be modelled. Hence, determination of basic engineering properties before design of a successful feed handling system is required. Therefore, an attempt was made to evaluate moisture content, bulk density, angle of repose, coefficient of internal friction and coefficient of external friction for three selected animal feed and fodder materials viz., oat green, wheat straw and concentrate mixture. The research outcome of such studies may be utilised to design and develop feed and fodder handling machines/devices and storage vessels/bins.

## Materials and Methods

### Raw materials

Green and dry animal feed materials (oat green, wheat straw and concentrate mixture) were selected for the study. Oat (*Avena sativa*) green, wheat (*Triticum*) straw and concentrate mixture (maize grass: 35%; deoiled rice bran: 13%; wheat bran: 12%; groundnut cake: 18%; soy de oiled cake: 19%; mineral mixture: 2% and common salt: 1%) were procured from fodder preparation unit, Livestock Research Centre, ICAR-National Dairy Research Institute, Karnal. Freshly cut oat green & wheat straw and dry powder of concentrate were procured for the study. Oats green and wheat straw harvesting were planned so as to maintain maximum nutrient content in fodder rather than in grains i.e. dough stage to beginning of flowering stage. Oat green and wheat straw were chopped into pieces (average length of 2.5 cm) using a chaff cutter before determining the properties.

### Determination of Angle of Repose

Angle of repose of selected feed and fodder material was determined using the developed setup in Research and Development Workshop according to method suggested by Chukwu & Akande (2007) with slight modifications.

A stainless steel 304 sheet of 2 mm thickness was cut in circular geometry with diameter 30 cm to be used as platform for keeping feed material to be evaluated. Steel plate was fixed at the centre of a hopper shaped galvanised iron container of 60 cm external diameter by welding support rods as shown in figure 1. A MS flat with slots at centre and sides was fixed with help of nut and bolt for inserting steel ruler for measurement of height during experiments. Distance between top face of steel plate and top surface of MS flat was measured as 30.7 cm to be used as a constant value for initial height.

The developed setup with outlet duct closure was placed on a levelled platform and proper horizontal level of steel plate was ensured by keeping spirit level on the steel plate. For measuring angle of repose of material, a heap of material was made by slowly pouring the material on the steel plate of the setup. As the heap grew in size, more material was added very carefully on the top of the growing heap till the heap of base diameter covered the full area of the steel plate and the feed material started to slide and fall off from the base plate edge into the outer container. Height of the heap ( $H_p$ ) was measured by putting MS flat on its place and inserting steel ruler through the centre slot to read value in centimetres. A short video indicating procedure for measurement of angle of repose has been uploaded to YouTube ([https://youtu.be/\\_55t6Fd9mnc](https://youtu.be/_55t6Fd9mnc)). Owing to the non-uniformity of feed material, measurements were done in seven replications for better accuracy. Equation (Eq. 1) as suggested by Sahay and Singh (1996) was used to calculate angle of repose.

$$\theta_r = \left( \frac{H_i - H_f}{D_p} \right) \quad (1)$$

Where,

$D_p$ : Plate Diameter = 30 cm  
 $H_i$ : Initial Height = 30.7 cm

### Determination of Bulk density

For measurement of bulk density a 250 mL beaker was filled with water up to the brim to check full volumetric capacity of selected beaker. It was found to be 300 mL, which was used for calculation of bulk density by ASTM D6683 method (ASTM 2014).

Selected beaker was tared on a precision electronic weighing balance (Model: KERRO BL3003; least count: 1 mg; capacity: 300 g). Feeding material for measurement of bulk density was

**Fig 1.** CAD drawing of angle of repose measurement setup

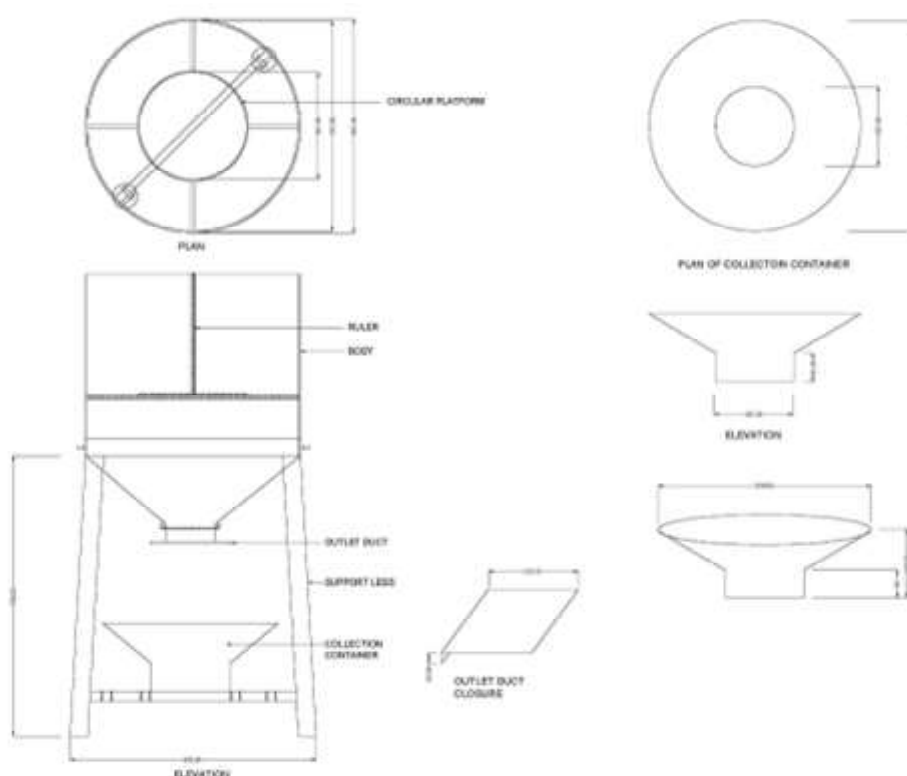

filled in the selected beaker till it overflowed. A spatula was used to gently remove extra material from top to create a flat surface at top of beaker. Weight of the filled beaker was noted. A short video indicating procedure for measurement of bulk density has been uploaded to YouTube ([https://youtu.be/\\_55t6Fd9mnc](https://youtu.be/_55t6Fd9mnc)). Bulk density was calculated by using the following equation (Eq. 2) (ASTM 2014)

$$\rho_{bd} = \frac{W}{V} \quad (2)$$

Where,

W: Weight of the material, kg

V: Volume of beaker, m<sup>3</sup> (fixed at 300 mL = 0.0003 m<sup>3</sup>)

#### Determination of coefficient of external friction

Coefficient of external friction of selected feed and fodder materials were determined by the method suggested by Sahay and Singh (1996) with slight modifications using the fabricated set-up in the Research and Development Workshop, ICAR – National Dairy Research Institute, Karnal.

A wooden plank was machined on lathe machine to make a hole to fit a container in the hole so that top edge of container would become coplanar with top surface of plank. Container/Pan to be inserted in the hole was cut out from a plastic jar. Wooden plank was cut in shape of rectangle. Plank was provided with four legs

of equal height. On one of the shorter side of plank a pulley was provided so that a string could be passed over it. A string of nylon fibre was selected to be used as it offers negligible frictional resistance. A small plastic pan of negligible weight was attached to one side of string using a small aluminium hook of negligible weight. Three cylindrical shaped metal containers without ends of different diameters and heights were chosen and a small slot was made on curved surface so as to pass string through it. Slots on metal containers were meant to adjust string in horizontal position when passing it through pulley hanging over to the pan as shown in figure 2. Five plates of different construction material were chosen and were cut so as to cover central hole in the wooden plank. Five plates were of Stainless Steel (AISI: SS-304), Mild Steel, Aluminium, Galvanised Iron and Ply Board. Selected plates had roughness average value 0.4, 1.5, 1.5, 1.0 µm for SS-304, Mild Steel, Aluminium and Galvanised Iron respectively within range of ± 0.1 µm. Locally available commercial ply board of 6mm thickness was used. Four clamps were made out of stainless steel to hold plates in place during measurements.

For the measurement of coefficient of external friction, the cylindrical shaped metal sample holder was placed on different plate surfaces (mild steel, aluminium, galvanised iron and ply board), which was connected to the weight pan by a nylon string. The weights were gently and carefully put in the pan so that no jerk was observed till the cylinder just started moving from the marked place and total weight in pan was noted as tare reading. Then the sample holder was filled with feeding material so that it

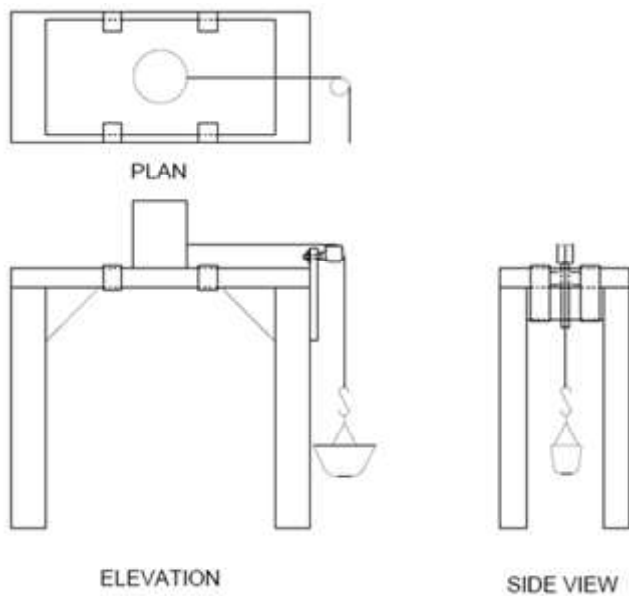

**Fig. 2** CAD drawing of angle of repose measurement setup

just overflowed from the top surface. A spatula was used to gently remove extra material from top to create a flat surface at top of container. Extra feed material was removed from the plate surface. Again weights were put in the pan and total weight that caused movement was noted as measured reading. Pulling force was calculated by subtracting tare reading from measured reading. A short video indicating procedure for measurement of coefficient of external friction has been uploaded to YouTube ([https://youtu.be/\\_55t6Fd9mnc](https://youtu.be/_55t6Fd9mnc)). Coefficient of friction was calculated using the following formula (Eq.3). Subramanian and Viswanathan (2007)

$$\mu = \frac{F_p}{N_p} \tag{3}$$

Where,

$F_p$  : weight in pan or pulling force  
 $N_p$  : weight in pipe or normal reaction

**Determination of coefficient of internal friction**

Coefficient of internal friction of selected feed and fodder materials were determined by the method suggested by Subramanian and Viswanathan (2007) with slight modifications using the fabricated

set-up in the Research and Development Workshop, ICAR – National Dairy Research Institute, Karnal.

The apparatus (as already described in previous section) consisted of one stationary container and one moving cylindrical sample holder. The container inserted in wooden plank was filled in with the sample without compactation and levelled off using a scale. The empty sample holder was gently put on the levelled surface of stationary sample container. Then weights were gently and carefully put in the pan so that no jerk was observed till the sample holder just started moving from its place. Total weight was noted as a tare reading. Then the sample holder was filled with the feeding material without compactation and the weights were put in the pan and total weight that caused the movement was noted as measured reading. The filled in sample holder was made to slide on the stationary container with the help of a pulley-nylon string arrangement. Pulling force was calculated by subtracting tare reading from measured reading. A short video indicating procedure for measurement of coefficient of internal friction has been uploaded to YouTube ([https://youtu.be/\\_55t6Fd9mnc](https://youtu.be/_55t6Fd9mnc)). Coefficient of friction was calculated using the following equation (Eq.4). Subramanian and Viswanathan (2007)

$$\mu = \frac{F_i}{N_i} \tag{4}$$

Where,

$F_i$  : weight in pan or pulling force  
 $N_i$  : weight in pipe or normal reaction

**Moisture content**

Moisture content was determined gravimetrically using AOAC (1975) method with some modifications. 2-3 g of sample was taken and moisture was removed till the sample obtained a constant weight using a hot air oven kept at 102±2°C.

$$M(\%wb) = \frac{W_1 - W_2}{W} \tag{5}$$

Where,

$W$  : weight of sample  
 $W_1$  : weight of pan with sample  
 $W_2$  : weight of pan with sample after constant weight

**Table 1** Different properties of feed material

Feed material	Moisture content (% wb)*	Bulk density (kg/m <sup>3</sup> )	Angle of repose (°)	Coefficient of internal friction
Oat green	64.27±11.45	455.03±11.52	37.79±0.76	0.187±0.024
Wheat Straw	12.07±0.88	40.42±1.76	36.51±1.11	2.628±1.612
Concentrate Mixture	11.74±0.71	504.25±1.82	24.78±0.34	0.357±0.048

\*wb: wet basis

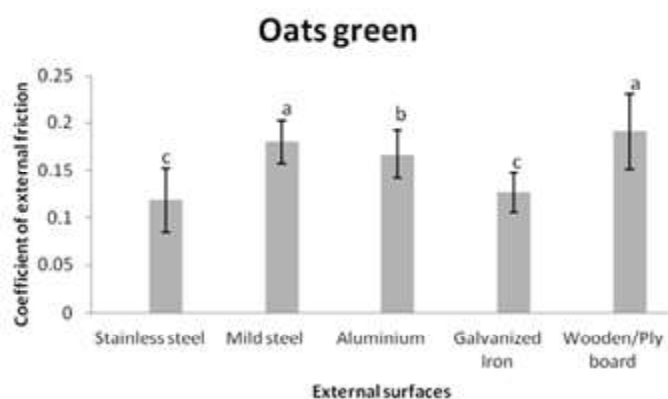

Fig. 3 Coefficient of external friction for oat green

### Statistical analysis

Moisture content, bulk density and angle of repose trials were replicated seven times and coefficients of internal and external friction values were taken in seven replicates at four different positions with two sample holders (56 effective replicates). Statistical analysis was performed using WASP- Web Agri Stat Package 2.0 of ICAR-Central Coastal Agricultural Research Institute, Goa.

### Results and Discussion

Physical and engineering properties including moisture content (%wb), bulk density, angle of repose, coefficient of internal and external friction of various animal feed materials were determined.

#### Angle of repose

Angle of repose of the selected feed materials was estimated using the developed angle of repose set up. Highest angle of repose value was observed for oat green ( $37.79 \pm 0.76^\circ$ ) and lowest angle of repose was observed for concentrate mixture ( $24.78 \pm 0.34^\circ$ ). Even though wheat straw was in dry form, it showed an almost similar angle of repose value ( $36.51 \pm 1.11^\circ$ ) of oat green. Makavana et al. (2018) had conducted studies on wheat straw and found similar values of angle of repose ( $38.23^\circ$ ). Bhople et al. (2017) carried out a study to understand the effect of moisture content on angle of repose for different cereals and pulses and they conclude that the angle of repose increased as moisture content of the grains increased. This reported finding is at par with the present study.

#### Bulk Density

The bulk density of oat green was  $455.03 \pm 11.52 \text{ kg/m}^3$ . McNulty and Kennedy (1982) reported the bulk density value of oat green to be  $439 \text{ kg/m}^3$  and the current observation was at par with their finding. Bulk density of wheat straw was found to be  $40.42 \pm 1.76$

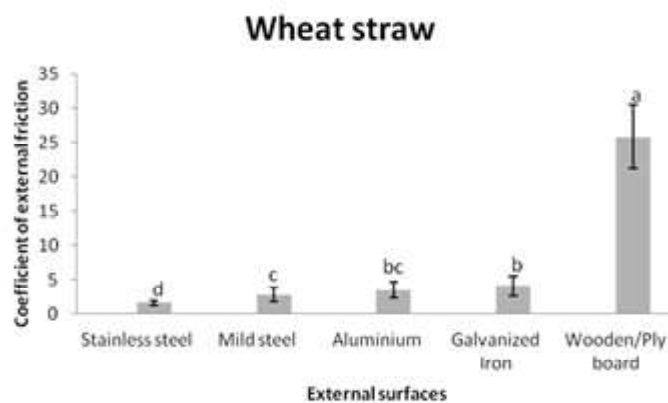

Fig. 4 Coefficient of external friction for wheat straw

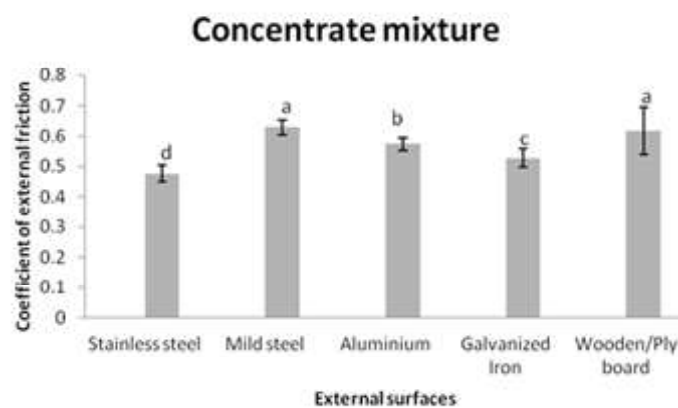

Fig. 5 Coefficient of external friction for concentrate mixture

$\text{kg/m}^3$ , which was in accordance with the observations of Guo et al. (2013). Lam et al. (2007) carried out a study to analyse the bulk and specific density of wet and dry wheat straw and they inferred that the bulk density increased with moisture content of particles. Highest bulk density among the tested samples was observed for concentrate mixture ( $504.25 \pm 1.82 \text{ kg/m}^3$ ). Bahnasawy and Mostafa (2011) had conducted studies on feed pellets and they reported the bulk density value of pellets as  $640 \text{ kg/m}^3$ . Thus, the values obtained in the current study were in corroboration with literature reported data. Tang et al. (2014) established a relation between moisture content and bulk density of biomass materials. According to them, the volume of the biomass will be larger if it has more moisture in it and therefore, the bulk density of biomass will be lower.

#### Coefficient of external friction

Coefficient of external friction between the fodder materials and surfaces of different fabrication material viz., stainless steel, mild steel, aluminium, galvanized iron and wooden/ply board were determined. Friction between stainless steel and all the three fodder materials were least whereas wooden/plywood offered highest resistance or friction to the fodder materials oat green

(Fig. 3) and wheat straw (Fig. 4). Friction between mild steel and concentrate mixture were highest while analysing the coefficient external friction of concentrate mixture (Fig. 5). Askari et al. (2017) observed and reported that the coefficient of external friction was influenced by product variety, grain moisture content, the material of contact surface, sliding velocity etc.

Coefficient of external friction between the selected feed materials with different surfaces including stainless steel, mild steel, aluminium, galvanized iron and wooden/ply board were determined. It was observed that the coefficient of external friction between oat green with mild steel and ply board were statistically similar and these surfaces offered highest friction. Whereas, stainless steel and galvanized iron surfaces offered least friction to oat green and those were statistically similar.

Coefficient of external friction between wheat straw with different surfaces were observed to be statistically significant. Wooden/ply board offered highest friction to wheat straw (25.88) whereas stainless steel offered the least friction (1.585). Frictional resistance between wheat straw with aluminium and galvanized iron were statistically similar. Aluminum and mild steel also showed statistically similar values of coefficient of external friction to wheat straw.

Wooden/plywood and mild steel offered the highest values of coefficient of external friction to concentrate mixture and stainless steel offered the least.

#### Coefficient of internal friction

Coefficient of internal friction is an important design parameter for storage and distribution of cattle feed materials. The values of coefficient of internal friction for oat green, wheat straw and concentrate mixture were  $0.187 \pm 0.024$ ,  $2.628 \pm 1.612$  and  $0.357 \pm 0.048$ , respectively. The reported range of coefficient of internal friction of wheat straw was 0.765-1.586 by Chevanan et al. (2008). There was observed a significant increase in the estimated coefficient of internal friction value of wheat straw. Also, there observed no correlation between moisture content and coefficient of internal friction of the selected materials. Mani et al. (2004) also reported that the adhesion coefficient did not exhibit dependence on moisture content of corn stover.

#### Moisture Content

Table 1 illustrates the values of moisture content (%wb), bulk density, angle of repose and coefficient of internal friction of selected feed materials. A significant deviation was observed in the values of moisture content for oat green during different trials with an average value of  $64.27 \pm 11.45$  (%wb). Gill and Omokanye (2018) studied the "Potential of Spring Barley, Oat and Triticale Intercrops with Field Peas for Forage Production, Nutrition Quality and Beef Cattle Diet" and reported the moisture content range of green fodder as 55-77 (%wb). Therefore, the

observed moisture content of oat green was in concordance with the earlier findings. The average moisture content of wheat straw was  $12.07 \pm 0.88$  (%wb). Guo et al. (2013) conducted a study on the physio-chemical properties of wheat straw and reported the moisture content value of wheat straw as 12.8 (%wb). Hence the observed moisture content value was at par with the literature value. The concentrated mixture had an average moisture content of  $11.74 \pm 0.71$  (%wb). Alengadan et al. (2013) studied the moisture content control during cattle feed production and they reported that the moisture content of cattle feed should not be more than 11.5% and the excess moisture content in cattle feed results in serious quality problems. In another study conducted by Bahnasawy and Mostafa (2011), the reported moisture content values for feed pellets was 16-17 (%wb).

#### Conclusion

Engineering properties of cattle feed materials play a key role in the design of a mechanised feed and fodder handling and distribution system. Therefore, important feed properties like moisture content, bulk density, angle of repose, coefficient of internal and external friction were determined for the selected feed materials viz. oat green, wheat straw and concentrate mixture. Laboratory scale equipments were developed for determining angle of repose and coefficient of friction. Moisture content and bulk density of the selected materials ranged from 11-65% and 40-500 kg/m<sup>3</sup>, respectively. Angle of repose and coefficient of internal friction; which play the key role in storage and distribution equipment design, ranged between 24-37° and 0.18 - 2.6, respectively. These insights into the feed properties will help to choose the appropriate material for fabrication as well as for the overall design and development of mechanised feed handling and distribution units. These data could be helpful in selection of material for fabrication of equipment.

#### Acknowledgement

Authors are thankful to the director ICAR-National Dairy Research Institute, Karnal for kind support in this research work.

#### References

- DAHD (2019) 20<sup>th</sup> Livestock Census, Department of Animal Husbandry and Dairying, Ministry of Fisheries, Animal Husbandry and Dairying, Govt. of India. Retrieved from <https://www.dahd.nic.in/sites/default/files/Key%20Results%2BAnnexure%2018.10.2019.pdf> (Accessed 25th September, 2022)
- A.O.A.C. (1975) Method of analysis of the association of analytical chemist, Pub. Association of Analytical Chemists, Washington, U.S.A.
- Alengadan PJ, Babu DE, Prakash MK (2013) Moisture Content Control During Cattle Feed Production -An Spc Based Approach. *Int J Eng Res Technol (IJERT)* 2: 1-4
- American Association of cereal chemists. approved methods committee. (2000) Approved methods of the American association of cereal chemists (Vol. 1). Amer Assn of Cereal Chemists

- AskariAsli-Ardeh E, Zadeh HM, Abbaspour-Gilandeh Y (2017) Determination of dynamic friction coefficient in common wheat varieties on different contact surfaces. *Agricultural Engineering International: CIGR J19*:136–141
- ASTM D6683 (2014) Standard test method for measuring bulk density values of powders and other bulk solids as function of compressive stress.
- Bahnasawy AH, Mostafa HM (2011) Some engineering properties of different feed pellets. *Misr J Agricul Eng* 28:947-960.
- Bhople S, Kumar A, Haldkar P (2017) Effect of moisture content on angle of repose for different cereals and pulses. *Int J Commun Sys* 5: 2283-2286
- Puchalski C, Brusewit, GH (1996) Coefficient of friction of watermelon. *Transactions of the ASAE* 39: 589-594
- Chevanan N, Womac AR, Bitra VS (2008) Loose-filled and tapped densities of chopped switchgrass, corn stover and wheat straw. In 2008 Providence, Rhode Island, June 29–July 2, 2008 (p. 1). American Soc Agric Biol Eng
- Chukwu O, Akande FB (2007) Development of an apparatus for measuring angle of repose of granular materials. *AUJT* 11: 62-66
- Dagar JC (2017) Potentials for fodder production in degraded lands. In P. K. Ghosh, S. K. Mohanta, J. B. Singh, D. Vijay, R. V. Kumar, V. K. Yadav, & S. Kumar (Eds.), *Approaches towards fodder security in India* (pp. 333–364). Studera Press New Delhi
- Gill KS, Omokanye AT (2018) Potential of spring barley, oat and triticale intercrops with field peas for forage production, nutrition quality and beef cattle diet. *J Agric Sci* 10:1916-9760
- Guo W, Yang J, Zhu X, Wang S, Guo K (2013) Frequency, moisture, temperature, and density-dependent dielectric properties of wheat straw. *Transactions of the ASABE* 56: 1069-1075
- Seville JPK, Tuzun U, R. Clift, *Processing of Particulate Solids*, Chapman and Hall, London, U.K., 1997
- Kumar S, Agrawal RK, Dixit AK, Rai AK, Singh JB, Rai SK (2012) Forage production technology for arable lands. *Technol Bull* 39: 255-260
- Lam PS, Sokhansanj S, Bi X, Mani S, Lim J (2007) Physical characterization of wet and dry wheat straw and switchgrass–bulk and specific density. In 2007 ASAE Annual Meeting (p. 1). American Soc Agric Biol Eng
- Larsson SH (2010) Kinematic wall friction properties of reed canary grass powder at high and low normal stresses. *Powder Technol* 198: 108-113
- Makavana JM, Agravat VV, Balas PR, Makwana PJ, Vyas VG (2018) Engineering properties of various agricultural residue. *Int J Curr Microbiol App Sci* 7:2362-2367
- Mani S, Tabil LG, Sokhansanj S, Roberge M (2004) Mechanical properties of corn stover grind. In 2003 *ASAE Annual Meeting* (p. 1). American Society of Agricultural and Biological Engineers
- McNulty PB, Kennedy S (1982) Density measurements of grass by toluene displacement and air comparison pycnometry. *Irish J Agric Res* 75-83
- Sahay KM, Singh KK (1996) *Unit operations of agricultural processing*. Vikas Publishing House Pvt. Ltd.
- Shashikala T, Susheela R, Naaiik RB, Shanti M, Devi KBS, Chandrika V, Murali B (2017) Forage resources of telangana state and research technology for enhancing fodder production. *Int J Econ Plants* 4: 162–169
- Subramanian S, Viswanathan R (2007) Bulk density and friction coefficients of selected minor millet grains and flours. *J Food Eng* 81: 118-126
- Tang JP, Lam HL, Aziz MKA, Morad NA (2014) Biomass characteristics index: a numerical approach in palm bio-energy estimation. In *Computer Aided Chemical Engineering* pp. 1093-1098
- Vijay D, Gupta CK, Malviya DR (2018) Innovative technologies for quality seed production and vegetative multiplication in forage grasses. *Curr Sci* 114: 148–154